

ELENCO PARTI				
EL EM EN TO	QT À	NUMERO PARTE	DESCRIZIONE	MATERIALE
1	1	R-ATEP642 (BOTTOM 400X400X8)	FINITURA LUCIDO A SPECCHIO	ACCIAIO INOSSIDA BILE 316L
2	1	R-ATEB4/H703 (PROFILO 200X200X2)	FINITURA LUCIDO A SPECCHIO	ACCIAIO INOSSIDA BILE 316L
3	1	R-ATEP643 (TOP 400X400X4)	FINITURA LUCIDO A SPECCHIO	ACCIAIO INOSSIDA BILE 316L

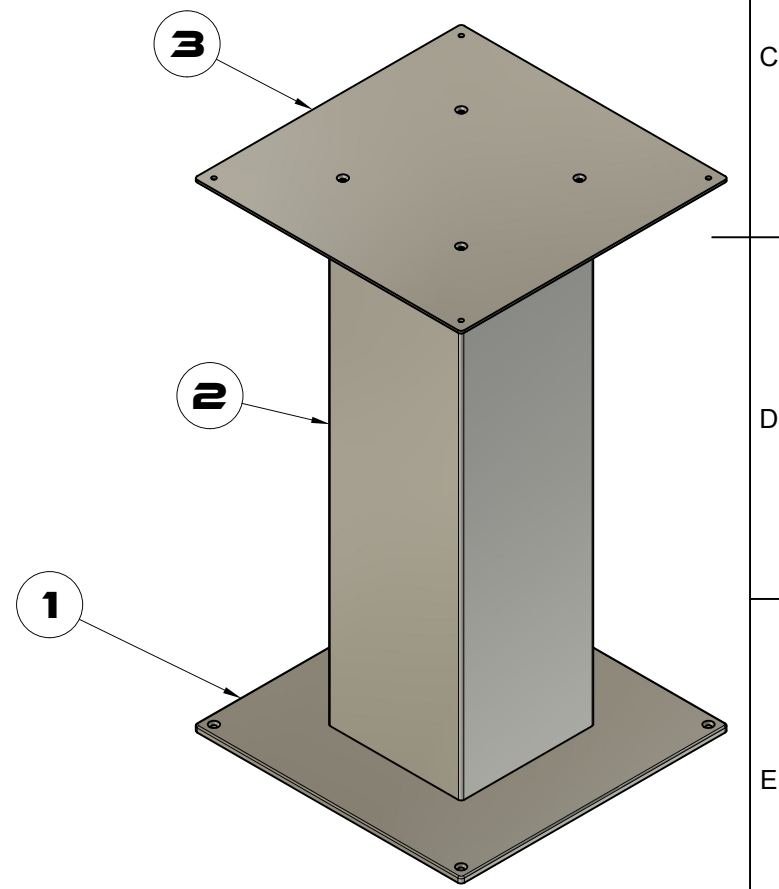

SCALE	FORMAT	CREATED BY	APPROVED BY	STATUS
1:6	A3	Andrea Luzzeri	Giuseppe Conzadori	
ATEP ITALIA ATEP ITALIA S.R.L. CONFORTABLE ERGONOMICS MARINE EQUIPMENT VIA VANZAGO, 20 25030 PARATICO (BS) I T A L Y TEL: +39 035913344 MAIL: INFO@ATEP.IT	PROJEC NAME	ITEM	MATERIAL	REV
	20.0070A/INOX (Htot 715mm)	20.0070A/INOX	Acciaio inossidabile 316l	SHEET
	ADDITIONAL INFO			MASS
Supporto tavolo Htot 715mm profilo quadro 200x200mm			26.36 kg	
<small>QUESTO DOCUMENTO E' DI PROPRIETA' ESCLUSIVA DI ATEP ITALIA S.R.L. E' VIETATA QUALSIASI FORMA DI RIPRODUZIONE O DI DIVULGAZIONE SENZA L'ESPLICITO CONSENSO DI ATEP ITALIA S.R.L.</small> <small>THIS DOCUMENT IS THE EXCLUSIVE PROPERTY OF ATEP ITALIA S.R.L. ANY FORM OF REPRODUCTION OR DISCLOSURE IS PROHIBITED WITHOUT THE EXPLICIT CONSENT OF ATEP ITALIA S.R.L.</small>				